

Management sofa
TECHNICAL FILE

Alex

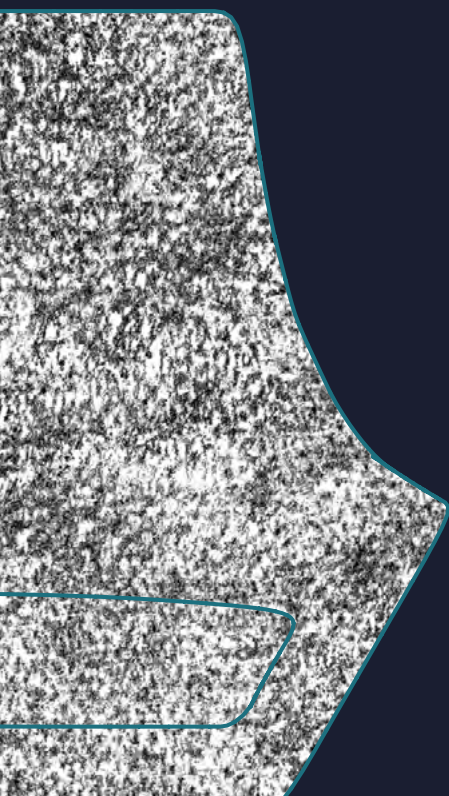

BOS
BARCELONA
— SINCE 1964 —

Materials, Finishes & Quality

- High quality wood structures from European beech.
- Seat and backrest with high quality molded foam fire-retardant, with high recovery capacity and good adapting performance.
 - Foam H.Q. Materialfilling
 - Ecological and resilient. Guaranteed to last with appropriate use.

Certifications :

Density kg / m³ (ISO 845). Compression strength (ISO 3386/1). Elongation (ISO 1798). Tensile strength (ISO 1798). Deformation remaining (ISO 1856 / A).

- Upholstery: Upholstered in different high quality materials:

1. Natural leather:

Hides are carefully selected among the best quality European rawhides. Pigmentation unifies the surface and masks natural hallmarks offering the optimum cutting yield and the pigmented finish also provides a soft feel and ensures extra protection against UVA and rub. The anti-stain finish combines warmth to the touch and easy maintenance.

Certifications:

Rub fastness : Dry (EN ISO 11640 / EN ISO 11641- Wet : EN ISO 11640 / EN ISO 11641). Light fastness (EN ISO 105 -B02). Tear propagation strength (EN 3377-1). Adhesion of finish (ISO 11644). Flammability (UNE EN ISO 1021-2)

2. Eco-Leather:

- a. Superior abrasion 300.000 cycles MARTINDALE
- b. Flame retardancy : EN ISO 1021 Part5 1 & 2

- Unique packaging in reticulated polyethylene foam. Triple layer of laminate polyethylene with hermetic bubbles 5x5 and density of 5400 bubbles/m². Corner protectors of high density reticulated polyethylene foam and cardboard box made to fit.

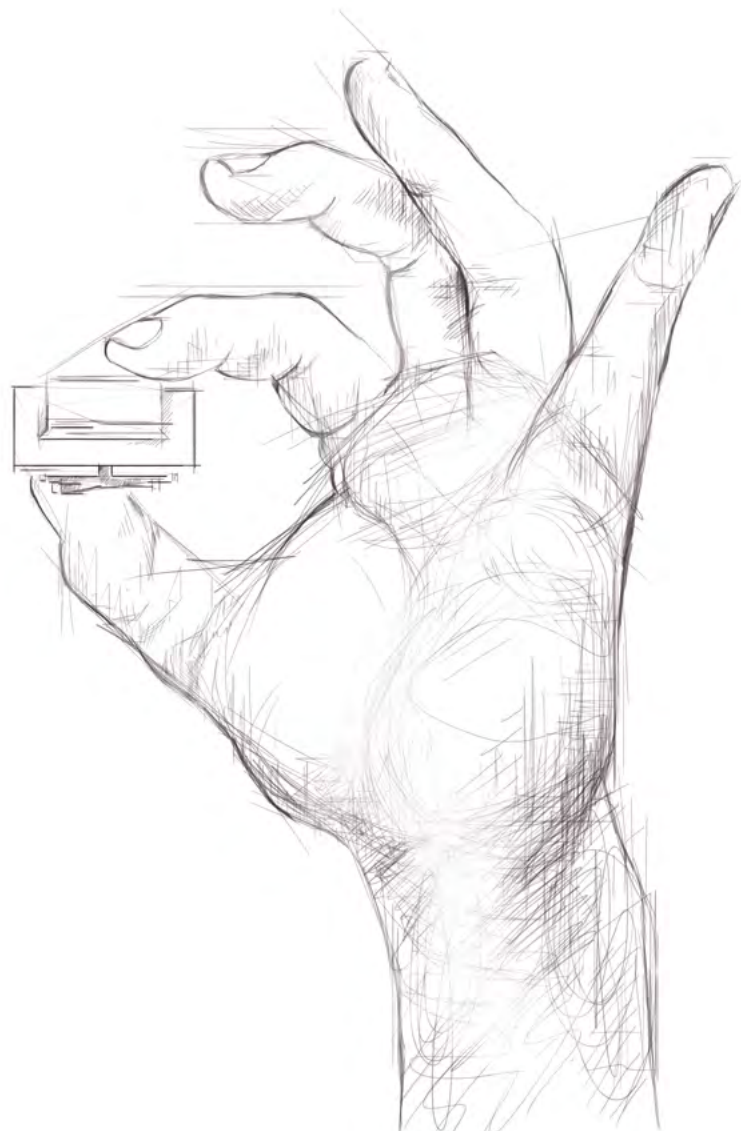

UNE-EN ISO
9001:2015

UNE-EN ISO
14001:2015

ALEX LOUNGE CHAIR

TECHNICAL PRESENTATION

Dimensions

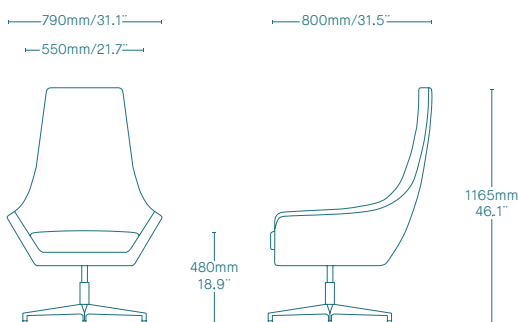
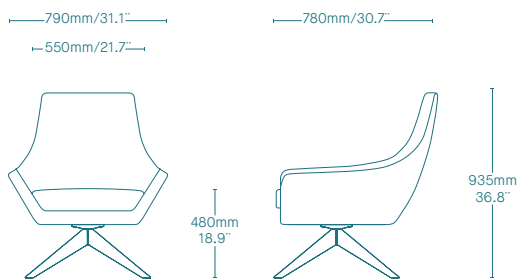
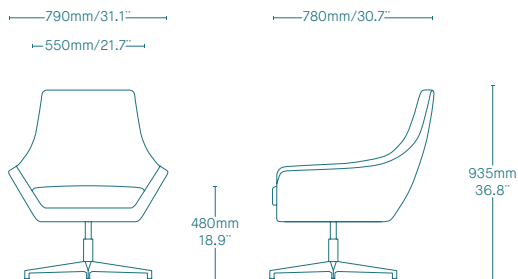

- **Armchair for top management offices and waiting areas.**
- **Upholstery:** upholstered in full grain leather, natural genuine leather or highly resistant leather imitations, as well as in other fabric finishes.
- **Base:** solid aluminium in polished finish or solid beech in different finish options.
- **Backrest:** two heights.
- **Additional optional headrest.**
- **Armrests:** armchair with structural armrests.
- **Matching coffee tables** with round and oval shapes.

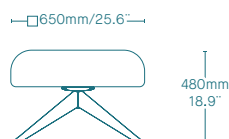
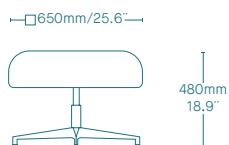
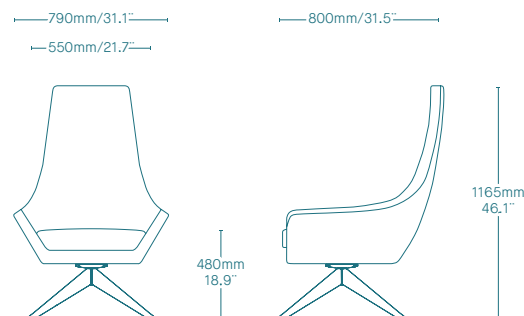

Occasional tables recommended

x64



ALEX LOUNGE CHAIR
MODELS





ALEX LOUNGE CHAIR FINISHES (BASE)

Natural wood veneers

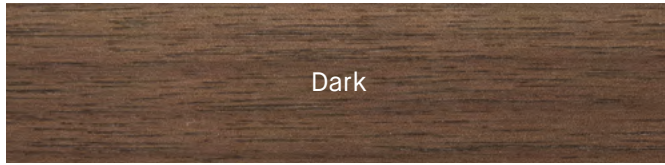

ALEX LOUNGE CHAIR FINISHES

leather

Full Grain Leather - serie 900 - *Category Leather*

979	949	929
913	916	902
907	954	939
911	947	927
967	937	941
942	909	920
930	945	922
904	914	925
900	935	943
908	944	912
903		

Natural Leather - serie 100 - *Category Leather*

179	136	126
131	142	117
113	127	121
197	125	103

ALEX LOUNGE CHAIR FINISHES

eco leather

Eco leather - Valencia - Category FAB1

8032	1048	1049
1001	0002	9001
4001	1050	0035
2020	6019	0033
6012	2075	2082
5001	5089	0020
3001	3089	3087
4040	4002	4045
4043	4041	4003
		9035

Eco leather - Chronos - Category FAB2

0001	0002	0003
0008	0004	0007
0005	0006	0009
0013	0011	0010
0018	0019	0020

Eco leather - Polaris - Category FAB2

3393	3635	4712
3895	4714	3884
6296	2070	2936
3540	3663	3685
2774	2882	565

ALEX LOUNGE CHAIR FINISHES

fabric

Fabric - Urban - Category FAB1

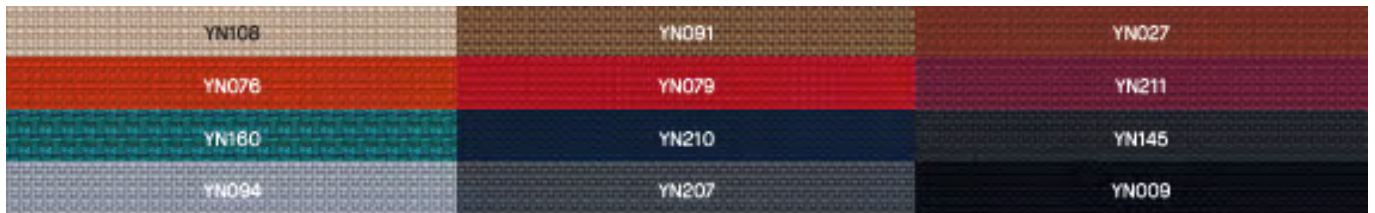

Fabric - X2 - Category FAB1



Fabric - Blazer - Category FAB2



Fabric - Main Line Flax - Category FAB2



Fabric - Aquarius - Category FAB2



ALEX LOUNGE CHAIR FINISHES (BASE)

Natural wood veneers

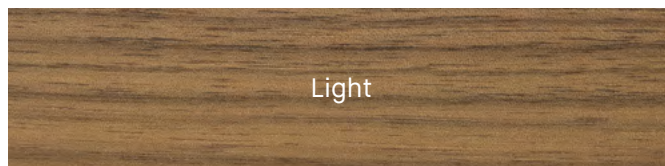
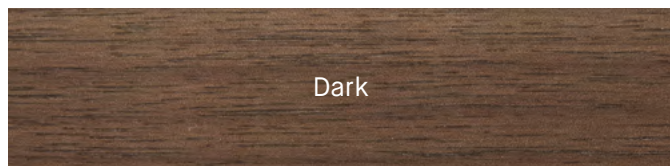





Diagonal 456
08006 Barcelona (Spain)

T +34 932 370 942
info@bos1964.com

 [bosbarcelona.com](https://www.bosbarcelona.com)

 Instagram
[@bosbarcelona](https://www.instagram.com/bosbarcelona)

 Facebook
[/bos1964](https://www.facebook.com/bos1964)

 LinkedIn
[Bos Barcelona](https://www.linkedin.com/company/Bos-Barcelona)

 Pinterest
[/bos1964](https://www.pinterest.com/bos1964)

 Youtube
[BOS Barcelona](https://www.youtube.com/BOS-Barcelona)